

Magnetic Bearing Overview

A magnetic bearing is an electromagnetic device used to maintain relative position of a rotating assembly (rotor) to a stationary component (stator). The electromagnetic forces are adjusted in response to forces generated from machine operation using an advanced electronic control system.

Auxiliary Bearing

Supports the rotor when the machine is stationary; accommodates overloads and supports the rotor in the event of system fault. The RDS® auxiliary bearing is comprised of a dry lubricated bushing mounted in a stator component and a special rotor component designed to reduce and dissipate heat during contact and coast-down.

Control System

Controls the position of the rotor by varying the current in the electromagnets in response to signals from the position sensor. The controls interface with other plant systems to allow proper start-up, operation and shutdown of the system.

Position Sensor

Provides instantaneous feedback of radial and axial rotor position to the electronic control system. Various position sensing technologies are employed, including inductive, eddy current, capacitive and magnetic depending on system performance requirements.

Radial Magnetic Bearing

Positions the rotor radially using four electromagnets; electromagnets are each comprised of a stator component and rotor component. The stator component is bolted to the machine housing while the rotor component is a sleeve fitted to the shaft and secured against rotation or axial movement.

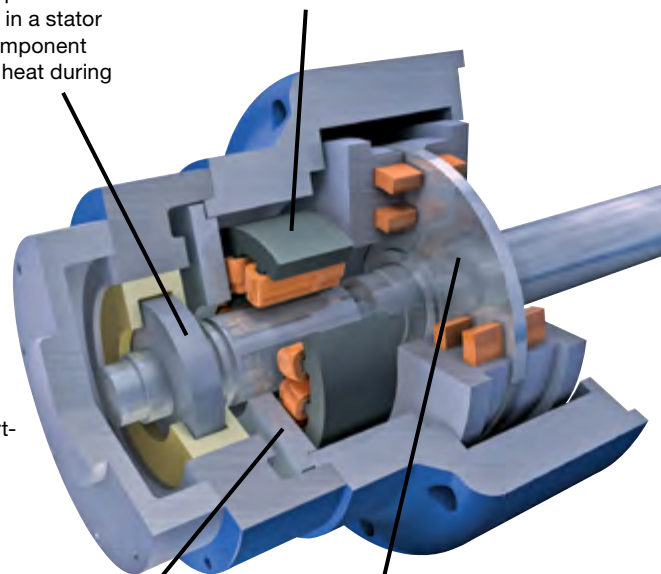

Axial Magnetic Bearing

Positions the rotor axially using electromagnetic forces pulling in opposition on the collar. The bearing collar is a flat, solid, ferromagnetic disc secured to the rotor; disc-shaped electromagnets are situated on either side of the collar and bolted to the machine housing forming the active and inactive axial bearing.

BENEFITS OF MAGNETIC BEARING TECHNOLOGY

- Increased reliability and availability – robust design with ongoing enhancements
- Environmentally friendly – no lubricating oil and reduced equipment profile
- Increased plant safety – fewer system interfaces
- Enhanced rotordynamic control – remote connectivity for monitoring and diagnostics
- Lowest total cost of ownership – reduced energy consumption, virtually maintenance free